



Certificate:

Capacitive Filling Level Probe - KFX

Series: **PER LEVEL COMPACT**

NPN Output - Antivalent

PNP Output - Antivalent

2 Limit value switching points / MIN/MAX-Control

- Integrated evaluation electronics
- Housing material: GFK, 16 mm Ø
- Connection head and process connection stainless steel VA
- Process connection 1"
- Probe length max. 2000 mm

Technical data

Active zone [mm]	10... 25, related to probe tip + 1 x type specific X2
Electrical version	4 connections DC
Output function	antivalent
Type NPN	KFX-5-2-"L"-15/X2-N-A-MM-VA-1"
Connection diagram No.	1
Type PNP	KFX-5-2-"L"-15/X2-P-A-MM-VA-1"
Connection diagram No.	2
Operating voltage (U _B)	18...36 V DC
Output current max. (I _O)	2 x 250 mA
Voltage drop max. (U _d)	≤ 2,5 V
Permitted residual ripple max.	40 %
No-load current (I ₀)	typ. 50 mA
Switching frequency max.	4 Hz
Permitted ambient temperature	- 25...+55°C
Permitted ambient temperature (for active zone)	-25...+100°C
Pressure	25 bar
LED-Display	green/yellow
Protective circuit	built-in
Degree of protection IEC 529	IP 67
Connection	Clamp terminal within the connection head
Housing material	VA No. 1.4571
Active zone	GFK

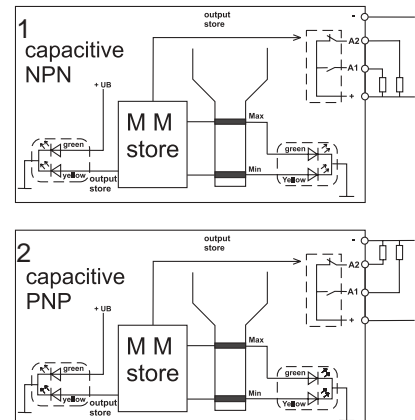
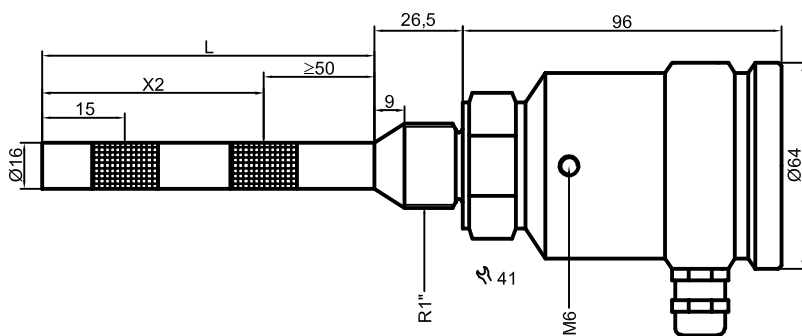

Other housing materials for the active zone (probe), like PE, PVDF or PEEK on request. Please determine the position of the second switching point "X2" when ordering.

All specifications are subject to change without notice. (05/2004)