



Capacitive Filling Level Probe - KFX
Series: ^{PER}LEVEL COMPACT
NPN Output - Antivalent
PNP Output - Antivalent
1 Variable limit value switching point

- Integrated evaluation electronics
- Housing material: GFK, 16 mm Ø
- Connection head and process connection stainless steel VA
- Process connection 1"
- Probe length max. 2000 mm

Certificate:



Technical data

Active zone [mm]	10...25, related to the probe tip + 1 x type specific xa
Electrical version	4 connections DC
Output function	antivalent
Type NPN	KFX-4-1-"L"-V10/xa-N-A-VA-1"
Connection diagram No.	1
Type PNP	KFX-4-1-"L"-V10/xa-P-A-VA-1"
Connection diagram No.	2
Operating voltage (U _B)	18...36 V DC
Output current max. (I _O)	2 x 250 mA
Voltage drop max. (U _d)	≤ 2.5 V
Permitted residual ripple max.	40 %
No-load current (I ₀)	typ. 50 mA
Switching frequency max.	4 Hz
Permitted ambient temperature	- 25...+55°C
Permitted ambient temperature (for active zone)	-25...+100°C
Pressure	25 bar
LED-Display	green/yellow
Protective circuit	built-in
Degree of protection IEC 529	IP 67
Connection	Clamp terminal within the connection head
Housing material	VA No. 1.4571
Active zone	GFK

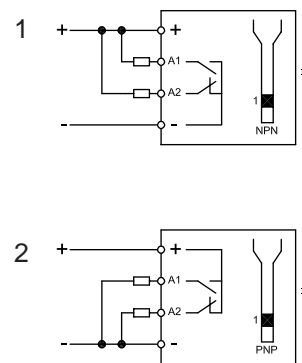
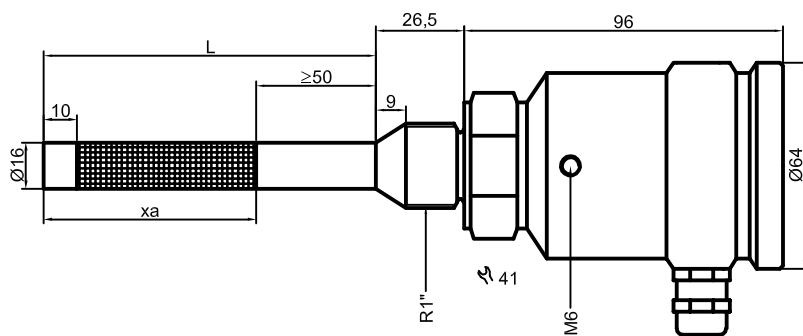

Other housing materials for the active zone (probe), like PE, PVDF or PEEK on request.

All specifications are subject to change without notice. (05/2004)