



**Capacitive Filling Level Probe - KFX**  
**Series: PER LEVEL COMPACT**  
**NPN Output - Normally Open**  
**PNP Output - Normally Open**  
**2 Variable limit value switching points**

- Integrated evaluation electronics
- Housing material: GFK, 16 mm Ø
- Connection head and process connection stainless steel VA
- Process connection 1"
- Probe length max. 2000 mm

Certificate:



**Technical data**

Active zone [mm]	10...25, related to the probe tip + 2 x type specific xa-Vxb/xc
Electrical version	4 connections DC
Output function	NO
<b>Type NPN</b>	<b>KFX-4-2-"L"-V10/xa-Vxb/xc-N-S-VA-1"</b>
<b>Connection diagram No.</b>	<b>1</b>
<b>Type PNP</b>	<b>KFX-4-2-"L"-V10/xa-Vxb/xc-P-S-VA-1"</b>
<b>Connection diagram No.</b>	<b>2</b>
Operating voltage ( $U_B$ )	18...36 V DC
Output current max. ( $I_o$ )	2 x 250 mA
Voltage drop max. ( $U_d$ )	≤ 2.5 V
Permitted residual ripple max.	40 %
No-load current ( $I_o$ )	typ. 50 mA
Switching frequency max.	4 Hz
Permitted ambient temperature	- 25...+55°C
Permitted ambient temperature (for active zone)	-25...+100°C
Pressure	25 bar
LED-Display	green/yellow
Protective circuit	built-in
Degree of protection IEC 529	IP 67
Connection	Clamp terminal within the connection head
Housing material	VA No. 1.4571
Active zone	GFK

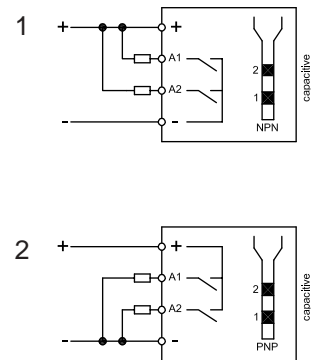
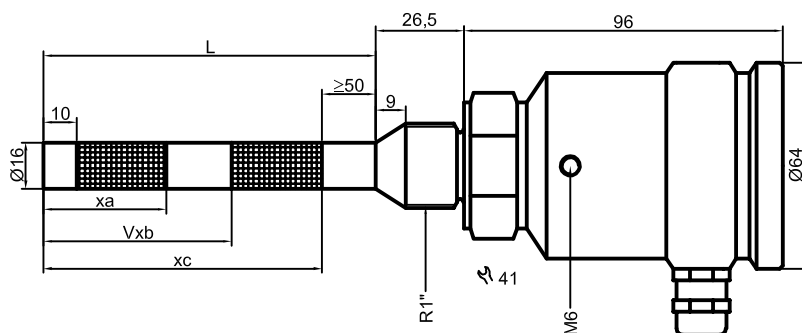

Other housing materials for the active zone (probe), like PE, PVDF or PEEK on request.  
 Please determine the position of the second switching points "V10/xa and Vxb/xc" when ordering.

All specifications are subject to change without notice. (05/2004)